

Light Dependent Resistor – based Electronic Eye Controlled Security System.

Yisau I. Bolanle

Department of Science Laboratory Technology, Federal Polytechnic, Ilaro, Ogun State, 111101, Nigeria.

E-mail: yisau.bolanle@federalpolyilaro.edu.ng

Adelaja O. Adebajo

Department of Science Laboratory Technology, Federal Polytechnic, Ilaro, Ogun State, 111101, Nigeria.

E-mail: adebajoadelaja@gmail.com.

Abstract: *Due to numerous security risks, entry to homes, workplaces, recreation areas, and communities must be controlled electronically. This project's electronically controlled automated security system will aid in preventing unauthorized access to regulated locations. The design and development of a shadow-sensing device for use in light-dependent home and office security systems is described by Electronic Eye. It offers the user an effective and dependable shadow-sensing security system for doors in homes and workplaces that supports the installation of LDR, the shadow sensor, and a buzzer (sound source) for security reasons. Additionally, the project focused on identifying unauthorized entry into residential and commercial premises, particularly in situations where inhabitants live distant from the door. The system is a straightforward and dependable shadow-activated security system that, in principle, revolutionizes living standards using sensor technology. For the majority of issues that homeowners encounter regularly, the system offers the most effective resolution. It is more versatile and economical because of the straightforward nature of its electronic components. The three components of the system are the power supply unit, which makes sure the circuit has a steady supply of power, the sensor unit, which detects shadows, and the alarm unit, whose primary job is to emit an audible sound to warn the host of the presence of guests or to frighten them away. System design was accomplished by taking into account several variables, including cost, design process efficiency, compatibility, and the availability of parts and research materials. Following testing, the system's performance complied with design requirements.*

Keywords: Light Dependent Resistor, Radio Frequency Identification, Regulator, Transistors

Introduction

An alarm is a loud sound or signal that warns or informs people of a threat or issue. Thus, an alarm system is a type of security system that sounds to alert individuals to a specific threat. With the creation of man, alarm systems began to evolve. Man needed to communicate alertly and developed a system of shouting, yelling, and gesturing. Town criers eventually replaced this with hand clapping and gong banging to notify the community and spread information in early African society. These alert-raising techniques were all clumsy, inconsistent, and ineffective. In the late 1700s, electronic alarm systems took the place of these antiquated alert-generating techniques due to scientific and technological advancements. These automated alarm systems don't require human intervention to function. Depending on how it is made, it will either make a loud noise or emit another signal when it detects a specific signal.

To detect the presence of unauthorized individuals, closed-circuit televisions are now integrated into burglar alarm systems. The output of burglar alarm systems can vary from loud alarms or sirens to telephone automatic dialers and flashing outdoor lights. This not only notifies the police but also serves as a signal to the neighbors of a potential intrusion. Auto dialers that are attached to

burglar alarms are programmed to dial 911 and play a recorded message informing the police that the house has been broken into (Nick A. Tim).

Thus, the concept of employing sensing devices for purposes of convenience, security, safety, and quality of service is not new; however, the system's application, cost, design approach, and reliability vary. (Zungeru *et al.*, 2012) examined the use of short messaging services to remotely operate home appliances and count the number of people inside a car using infrared radiation for both security and convenience. In contrast, Thomas (1994) created a burglar alarm system using an entire electrical circuit loop that is closed with a siren or bell at the output to notify the owner of anything that needs to be secured.

Many perimeter guards and motion detectors are monitored by a central control box, which sounds an alarm if any of them are activated. Certain burglar alarms relied on the use of touch or magnetic contacts. Furthermore, the majority of the previously described works do not take cost, durability, or dependability into account during the design process. Most importantly, this circuit used straightforward and readily available components to accomplish its intended goals. However, the primary drawback of this system is that it uses a

telephone to identify visitors, which means that anyone approaching the gate can use the phone.

According to Arulogun, Olaniyi, and Ipadeola (2009), the creation of a computer-controlled security gate system enables privileged users to enter through a keyless door with smart card authentication. It is a fact that smart cards are susceptible to theft, jeopardizing the system's security. To enter through the door, an attacker merely needs to obtain a working smart card. An electromagnetic door lock can be controlled by a user who enters the correct password on a keypad to obtain admittance using a low-cost private office access control system (Khan, 2012).

One significant flaw in the system is that passwords can be shared amongst others without the owner's consent. A rogue could log into the system using the password that was stolen. Microcontrollers and radio frequency identification (RFID) have been used to operate gates so that cars can pass through. (Olatinwo & Shoewu, 2013) has detailed a system in which infrared transmitters and microcontrollers are used to electronically operate swing gates.

This system has very few security features and is only needed to open and lock gates. Adewuyi, Okelola, and Jemilehin (2013) employed cameras to record and replay the driver's face and the license plate numbers of the vehicles. These are restored data recorded in a databank for later comparison with guests who will only be permitted admission through gates into a compound if the data match. The system's drawback is that customers can't travel through the gate unless they have accurate documentation. However, the system developed for this work uses a light-dependent resistor as a shadow sensor, which triggers an alarm when it detects a shadow thrown on it.

Materials and Methods

Materials used for the project are;

- Regulator(U1)
- Resistors (R1, R2)
- 1N8 diode (D1,D2)
- Capacitors (C1, C2)
- BC 547 transistors (Q1,Q2)
- 7404 IC U2
- Light Dependent Resistor(LDR1)
- Buzzer (BUZ1)
- Light Emitting Diode(LED1)
- DC 9V battery

The block diagram depicted in Figure 1 reflects the key components of the Electronic Eye Security System's construction, including the battery, power supply unit,

logic circuit, LED, and buzzer. The diode 1N4007 was connected in a forward bias condition to protect the circuit from negative voltages and permit current to flow in a single direction. The circuit as it is depicted in fig. 3 and 4, as powered by a 9-volt DC battery. To control the voltage across the circuit, regulator 7805 was connected. The logic circuit, fig. 1, received a constant voltage (5 volts) at the regulator's output because two transistors were connected before (Q1 inverts the input) and after (Q2 drives the buzzer) the regulator. A 220kΩ resistor was connected in series with the LDR at the logic circuit. The LDR (fig. 2) functioned as a shadow detector, activating the base of Q1. Voltage is then passed through the collector to turn on LED d2, which acts as an indicator when the LDR detects a shadow. Finally, voltage passed through the base of Q2. A buzzer was linked to Q2's collector to generate sound (fig. 1).

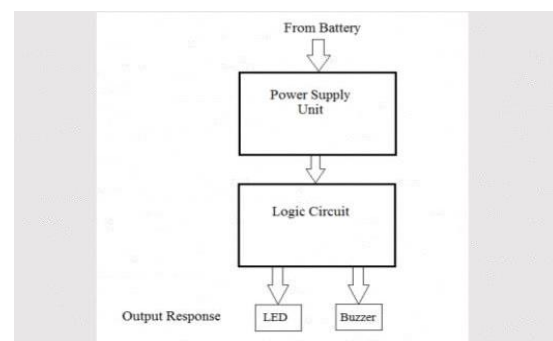

Fig. 1: Block diagram of Electronic Eye Security System

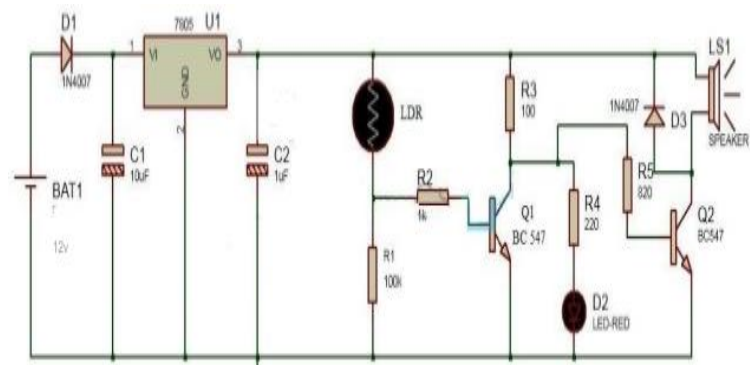

Fig. 2: Circuit diagram of Electronic Eye Security System.

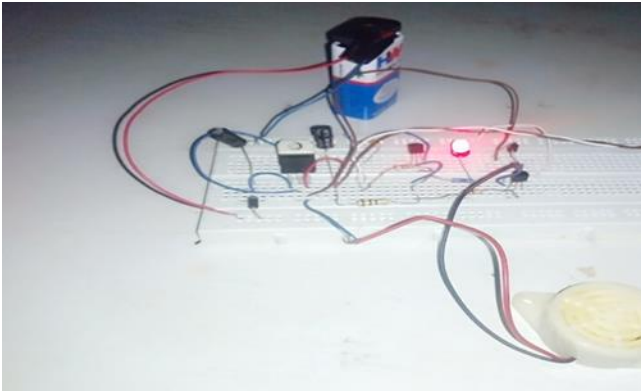

Fig. 3: Circuit on Breadboard.



Fig. 4: Circuit on Veroboard in the Active Stage



Fig. 5: Electronic Eye Security System.

Table. 1: Components Collection

COMPONENTS	SYMBOLS	RATINGS\VALUES
Regulator	UI	7805
Capacitors	C1,C2	10 μ F,1 μ F
Resistors	R1,R2,R3,R4	100k Ω ,1k Ω ,100k Ω ,&820k Ω
Transistors	C1,C2	BC547
Light Emitting Diode	D2	RED
Light Dependent Resistor	LDR1	
Diode	D1,D3	IN4007
Buzzers	LSI	
Battery	BAT1	9v

Results

emf = 9v

Output voltage, $V_o=6.4v$

$V_{cc}=2.6v$

FOR $Q_1=Q_2$

Table. 2: Results obtained from the device

LDR OFF	LDR ON
$V_{c1} = 0.30V$	$V_{c1} = 1.80V$
$V_{b1} = 0.95V$	$V_{b1} = 0.80V$

Total current, $I = I_c + I_b$

Since $R_3 = 100k\Omega$

$$I_c = \frac{V_c}{R_3} \text{ (Ohm's Law)}$$

$$\text{Where, } I_c = \frac{1.80}{100000} = 0.000018A$$

$$I_b = \frac{V_{b1}}{R_2+R_1}$$

Given, $R_2 = 1k\Omega$ and $R_1 = 100k\Omega$

$$\text{So, } I_b = \frac{0.8}{101000} = 0.0000079A$$

Therefore, $I = 0.000018 + 0.0000079$

$$I = 0.000026A$$

Discussion

V_c and V_b denote voltages at collector and the base of transistor, Q_1 , 0.30 and 0.95V respectively. When the device is inactive state (Table. 2). If the device is turned on, V_b decreases from 0.95 to 0.80V and V_c increases from its initial value to 1.80V (fig. 5). The circuit was supplied by a 9-volt battery, but only 8.3 volts passed through the regulator 7805, while 2.6 volts emerged as V_{cc} . As a result, when the LDR is off, or when there is no shadow on the LDR, a high voltage passes through the base of Q_1 , and when the LDR is on, or when it detects a shadow, a lower voltage passes through the base of Q_1 . When the circuit is turned on, the LED lights on and the LDR is ready to detect shadows. The signal is passed to Q_1 , which then triggers Q_2 , which causes Q_2 to turn on the buzzer. The speaker produces a stronger sound in proportion to the darkness of the shadow.

Conclusion and Future Works

In this project, an electronic eye security system has been successfully designed and constructed. The system notifies visitors in the event of an intruder or serves as an electronic security system. Consequently, by employing the Light Dependent Resistor to sense a picture and transmit a signal to the Light Emitting Diode and buzzer to alert the host, the system attains a respectable level of security.

References

- Adewuyi, P.A., Okelola, M.O. & Jemilehin, A.O. (2013).
An intelligent gate controller using a personal
computer and pattern recognition protocols,
*International Journal of Computational
Intelligence and Information Security*, 13-20.
- Arulogun, O.T., Olaniyi, O.M. & Ipadeola A.A. (2009).
Development of a computer-controlled security
gate system, *The Pacific Journal of Science and
Technology*, 9(2), 371-376
- Khan, S. R. (2012) Development of low cost private
office access control system, *International
Journal of Embedded Systems and Applications*,
2(2), 1-7.
- Nick A. Tim, "Technical leaflet on introduction to fire
detection and Alarm", *Security Systems
Engineering Division, North Charleston, U.S.A*,
67-86
- Olatinwo, S.O., Shoewu, O. (2013), 'Development of an
automated parking lot management system',
African Journal of Computing and ICT', 6(1),
95-108
- Thomas, P. (1994), "The alarm, sensor and security
circuit book", 'TAB Books'. Imprint of
McGrawhill San Francisco, U.S.A, 5-7
- Zungeru, A.M., & Kolo, J. G., (2012). Design and
Implementation of a Low Cost Digital Bus
Passengers's. *School of Electrical and
Electronic Engineering, University of
Nottingham, Jalan Broga, Malaysia*.